

522SMART

825B037H

Compact ultrasonic level transmitter with 2 thresholds and RS485 communication port

Technical Data

Housing material:	PBT
Mechanical installation, depends to the version:	-2 1/2" PP bracket -DN150 PN6 PP flange
Mechanical protection:	IP65
Electrical connection:	Internal plug-in connectors
Working Temperature:	-20 a +50°C
Pressure:	from 0,7 to 1,3bar (absolute)
Power supply, depends to the model:	24Vdc o 24,115,230Vac
Power consumption:	max 3,5W
Analog output:	4÷20mA max load 750 ohm
Relays output:	n°2 N.O. contacts 5A 230Vac
Communication port:	RS485
Max measure range:	15m
[the above range must be intended from reflecting surfaces]	
Blocking distance:	min 0.7m
Automatic frequency tuning:	built-in
Temperature compensation:	PT100 from -20 to +50°C
Accuracy:	+/- 1%
Resolution:	3mm
Calibration:	2 keys or by PC
LEDs display:	green LED flashing for echo receiving yellow LEDs for rel1 and rel2 actions

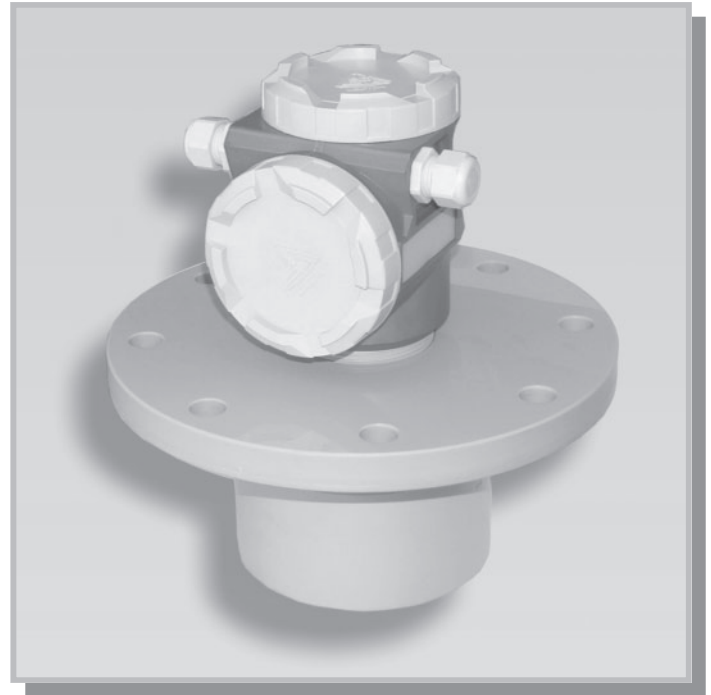

fig.1

522SMART Mechanical installation

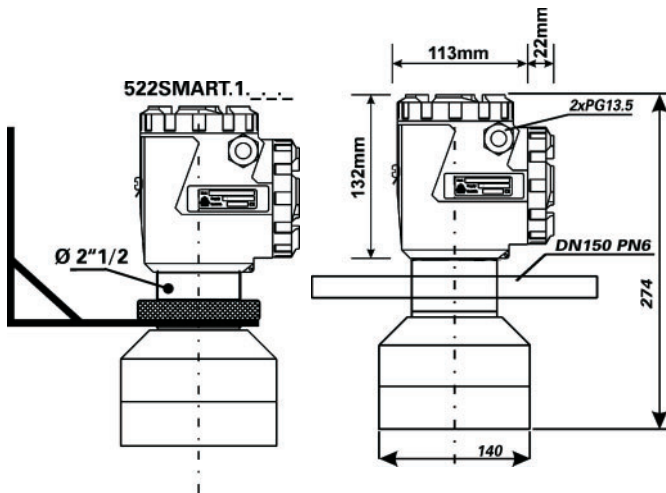

fig.2

fig.3

During the installation take in consideration the "blind zone"(0,7m), in which the sensor cannot measure. The sound waves from the transducer are transmitted in the shape of cone consequently, to avoid spurious echoes, is necessary to select the position of the ultrasonic transmitter in order to avoid interferences with obstacles or other. If application with granulate and powders the 522SMART would installed in a 2/3 of radius on the external side, far from the filling hole and aiming in the direction of the bottom discharge point (see fig.14).

The mechanical protection available is IP65. As no contact with the material to be measured is involved the device requires no maintenance.



LEKTRA

applied solutions for the applications

522SMART Electrical Connections

The 522SMART must be supplied with the voltage-supply selected at the order code. The current consumption is less than 6,0W that means for 24Vdc power supply less than 200mA. To access to the electrical connection (IP65), remove the cover unscrewing and opening the upper part, gain the access to two 6-pole plug-in connectors. Electrical connection must be made with a multi-wires round cable of proper diameter, otherwise the seal of the cable gland may be impaired. No special cable or coax-cable are requests, and no practice distance limits. For the Vdc power supply take in consideration that the negative of the power supply is electrically connected to the negative output current. Vac power supply versions, output current is galvanic separated. The electrical connections can be made by means a junction-box. A special J-box with P1 and P2 calibration push buttons built-in is available on request, it allows 522SMART remote calibration (avoiding to use the P1 and P2 push-

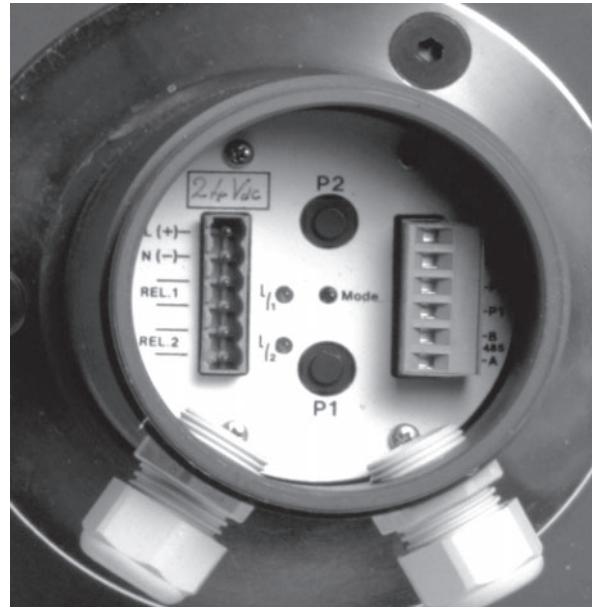
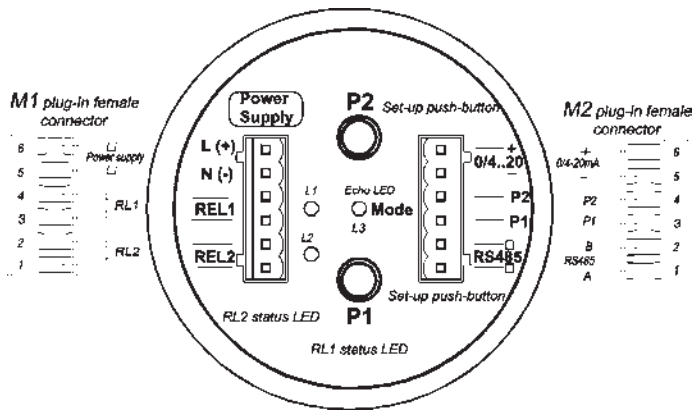

fig.5



buttons into the 522SMART when the installation give the calibration access difficult). The picture below shows the connectors and the push buttons for standard IP65 version calibration. Available a RS485 serial port to communicate to PC or PLC. On request the "76" S/W communication for PC and the RS485/RS232 conversion module are available. S/ W communication allow a PC 522SMART configuration and calibration, see the relevant documentation.

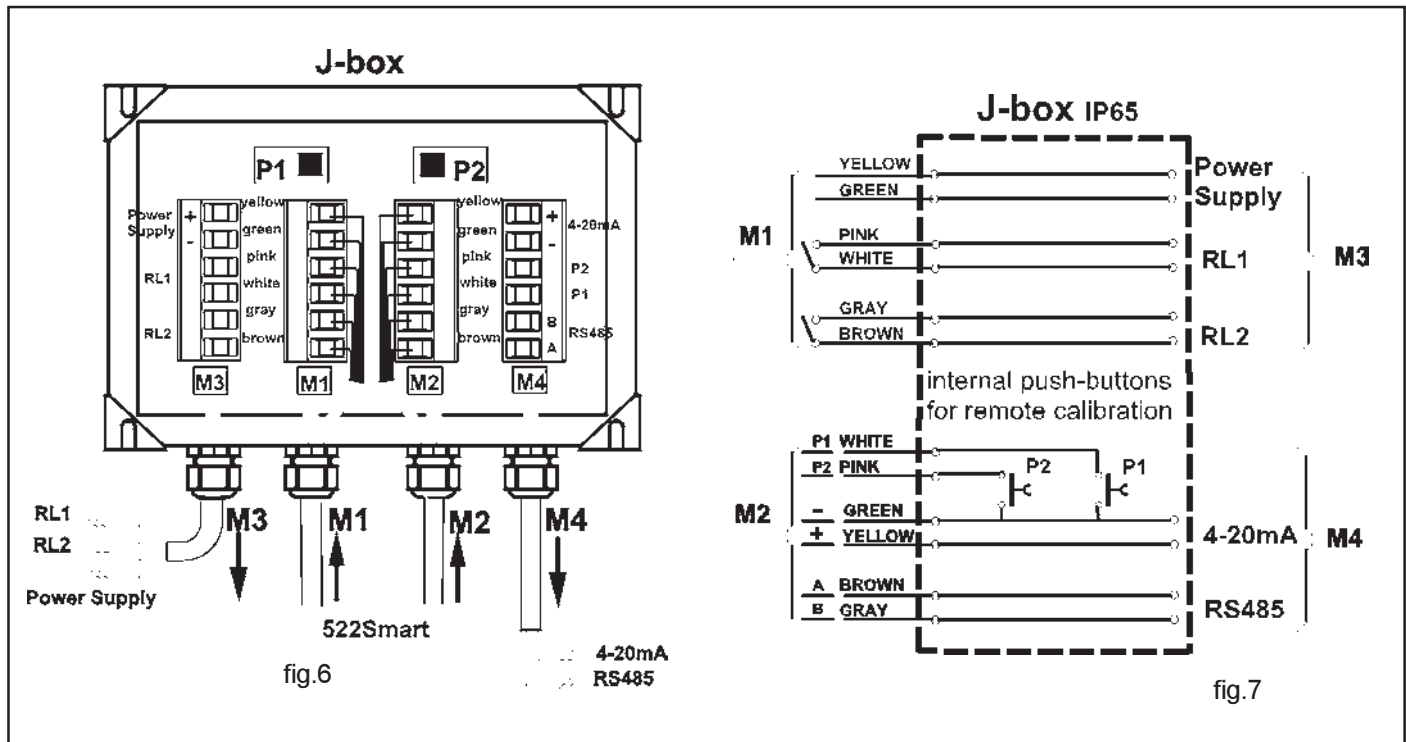

fig.6

fig.7

522SMART Calibration

The 522SMART calibration can be done in two different ways:

- a) By means the P1 and P2 keys.
- b) PC or PLC soft. communication with RS485 port.

a) To calibrate by-means 2 keys P1 and P2 (see fig.5), needs to put the "522SMART" respectively at the distance refers to 0% and 100% level, in order to memorise the distances electronically. 522SMART shows green L3 MODE(echo led) flash (when echo is received), in the condition of normal working.

To calibrate 4mA needs to put the 522SMART at the distance at which you want 4mA output current. Wait till the L3 is flashing than: press simultaneously P1 and P2, release them and verify that L3 will stay fix lightened.

Press two times P1, release it and wait until L3 is flashing again before move the sensor. The distance has been memorised and associated to 4mA output.

To calibrate 20mA needs to put the 522SMART at the distance at which you want 20mA output. Wait till the L3 is flashing than: press simultaneously P1 and P2, release them and verify that L3 will be fix lightened.

Press two times P2, release it and wait until L3 is flashing again before move the sensor. The distance has been memorised and associated to 20mA output.

The 522SMART factory relays configuration;

RL1, min distance alarm (max level alarm)

RL2, max distance alarm (min level alarm)

To calibrate the threshold of minimum distance (maximum level) needs to put the 522SMART at the distance at which you want minimum distance set-point, waiting till the L3 is flashing than: press simultaneously P1 and P2, release them and verify that L3 will stay fix on. Press P2 and release it, press P1 and release it. Wait until L3 is flashing again 10s before move the distance. The threshold of RL1 has been memorised.

To calibrate the set point (threshold) of max distance (minimum level) needs to put the 522SMART at the distance at which you want max distance set-point, waiting till the L3 is flashing than: press simultaneously P1 and P2, release them and verify that L3 will stay fix on. Press P1 and release it, press P2 and release it. Wait until L3 is flashing again for 10s before to move the distance. Threshold of RL2 has been memorised

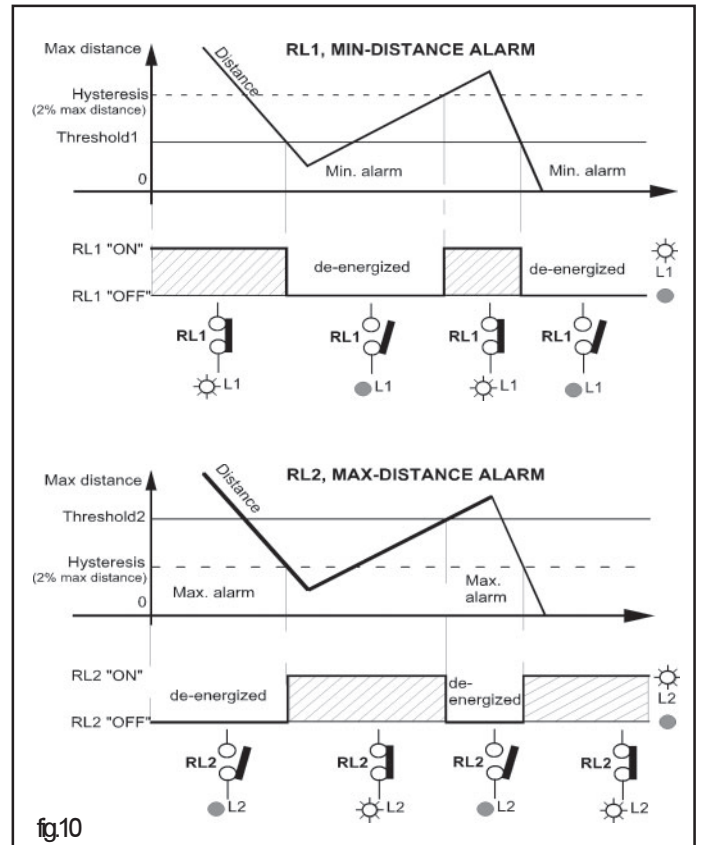

fig.10

- b) PC or PLC soft. communication with RS485 port. **Please refers to the relevant communication S/W documentation**

run	calibration	enter setpoints	run
Mode flashing	Mode fix lighted P2 P1	Mode fix lighted x y + P1 + P1 = 4mA P2 + P2 = 20mA P1 + P2 = RL2 P2 + P1 = RL1	Mode flashing

"LC" S/W COMMUNICATION

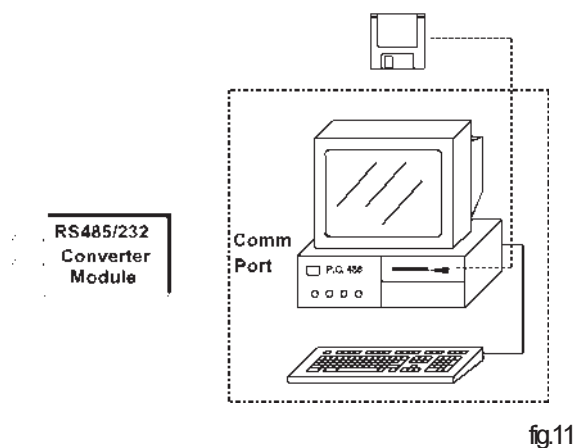
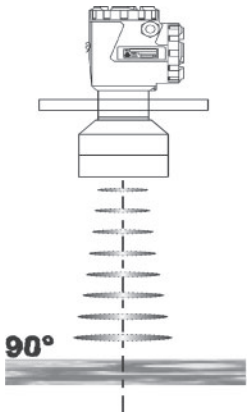
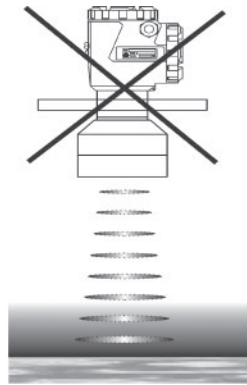

fig.11

522SMART Applications



Install perpendicular at the surface



Don't use with foaming products

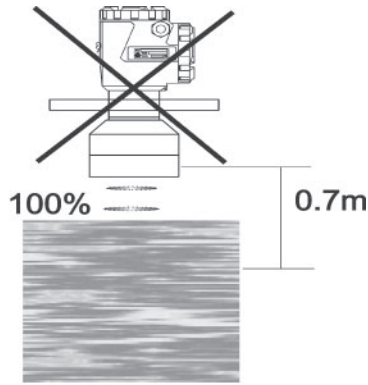

Avoid installation where the product distance could be less than 0,7m

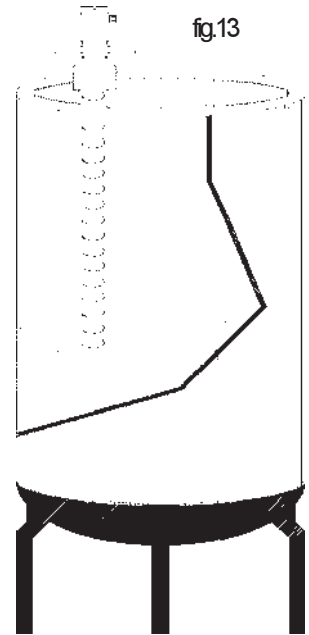

fig.13

Contact less continuous level measurement for liquids and muds

522SMART Warranty

Products supplied by SGM LEKTRA are guaranteed for a period of 12 (twelve) months from delivery date according to the conditions specified in our sale conditions document. SGM LEKTRA can choose to repair or replace the Product. If the Product is repaired it will maintain the original term of guarantee, whereas if the Product is replaced it will have 12 (twelve) months of guarantee.

The warranty will be null if the Client modifies, repair or uses the Products for other purposes than the normal conditions foreseen by instructions or Contract.

In no circumstances shall SGM LEKTRA be liable for direct, indirect or consequential or other loss or damage whether caused by negligence on the part of the company or its employees or otherwise howsoever arising out of defective goods

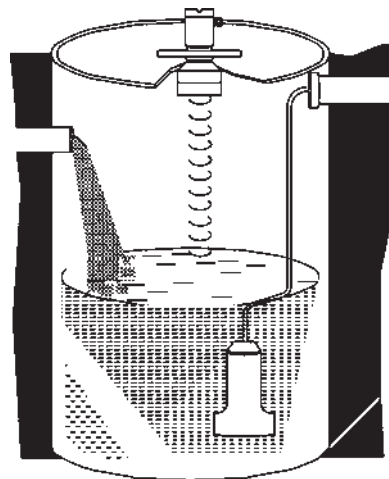

Compact pump controller for filling and emptying, this function can be selected by RS485 and S/W "LC" only

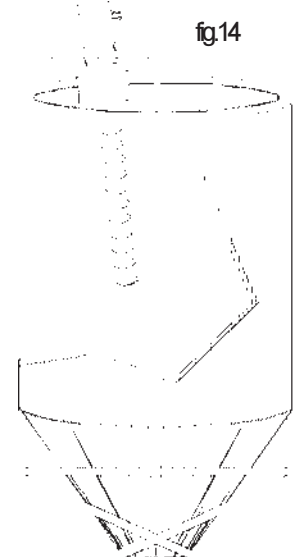

fig.14

Contact less continuous level measurement in tank and silos with bulk materials and granulates

522SMART Factory test certificate

In conformity to the company and check procedure I certify that the equipment:

522SMART Serial n.

is conform to the technical requirements on Technical Data and it is made in conformity to the procedure Quality Control Manager

.....
Production and check date

On request factory calibration:

4mA:

20mA:



LEKTRA

KEMA CERTIFICATE



SGM LEKTRA s.r.l.

Via Papa Giovanni XXIII, 49
20090 Rodano (Milano)

tel. ++39 0295328257 r.a.

fax ++39 0295328321

e-mail: info@sgm-lektra.com

web: www.sgm-lektra.com