

# MAP Mix Data Sheet

## Proportional gas mixers for industrial applications

- with full detection of too low gas inlet pressure



### Introduction to the MAP Mixers

The MAP Mix series is based on a proportional mixing principle especially designed for packaging machines and other industrial applications where the gases Nitrogen, Carbon dioxide and Oxygen are used, either in a 2-gas or 3-gas combination.

The mixing principle of the MAP Mix series is very strong and can be used for all types of packaging machines, e.g. flow packing machines and gas vacuum packing machines as well. The PBI-Dansensor gas mixer is very user-friendly with high accuracy - also under conditions, which usually cause problems for the repeatability of most other mixers.

The mixer features detection of too low gas inlet pressure with an alarm relay output to the external control. The standard version of the mixer can among others be combined with the microprocessor controlled high quality oxygen analyser MAP Check Combi from PBI-Dansensor.

### Accuracy and optimal blending quality

The MAP Mix series offers an unprecedented linearity in the 15-100% flow range and 10-90% mix settings.

Deviating pressure conditions on the outlet side have, due to the design of the proportional pressure system, virtually no effect on the accuracy. (See fig. 2 on the back of this page).

### Features

- High accuracy for optimal mixing quality
- Proportional gas mixing principle
- Prepared for use with microprocessor controlled oxygen analyser
- Electronic alarm for too low gas inlet pressure
- High flow rate
- Robust industrial design made in stainless steel/ aluminium
- Easy mixture adjustment
- Optional ON/OFF solenoid valve for gas flow (to shut off the gas flow on flow packaging machines when packaging machine stops)

### Gas mixer / gas analyser

For some applications it is an advantage to have the gas mixer and the gas analyser together. PBI-Dansensor offers a microprocessor controlled oxygen analyser MAP Check Combi, which physically can be mounted together with our mixers.

The analyser, Map Check Combi, is based on a high accuracy zirconium sensor, developed and manufactured by PBI-Dansensor and featuring complete self-diagnostics, semi-automatic calibration, built-in pump and two alarm levels for O<sub>2</sub> concentrations. This product is developed to work with our proportional gas mixers on vertical and horizontal flow packing machines.

### Flexible and ready to install

All our gas mixers will be delivered pre-adjusted and ready to install. PBI-Dansensor also offers electronic gas mixers, which as a special feature will be prepared for easy change of different pre-selected gases. This means that the user easily and safely can change between a number of different gases to be used with the mixer.

### Electronical gas mixer

The new generation of electronic gas mixers from PBI-Dansensor can be controlled via a PC user interface or from a PLC, which allows the user to define a new mix rate or quickly and easily change to a pre-defined setting. The electronic gas mixers are prepared for implementation in "LabVIEW," a powerful graphical development environment for signal acquisition, measurement analysis and data presentation. (Please ask for separate information)

## Mixing principle

All our mixers are utilizing the advantage of proportional mixing, which means that the mixing is carried out via proportional pressures on the two sides of a diaphragm. This diaphragm »absorbs« the deviation in the inlet pressure which normally causes changes in the mixing conditions, such as change of the flow rate. (See fig. 1).

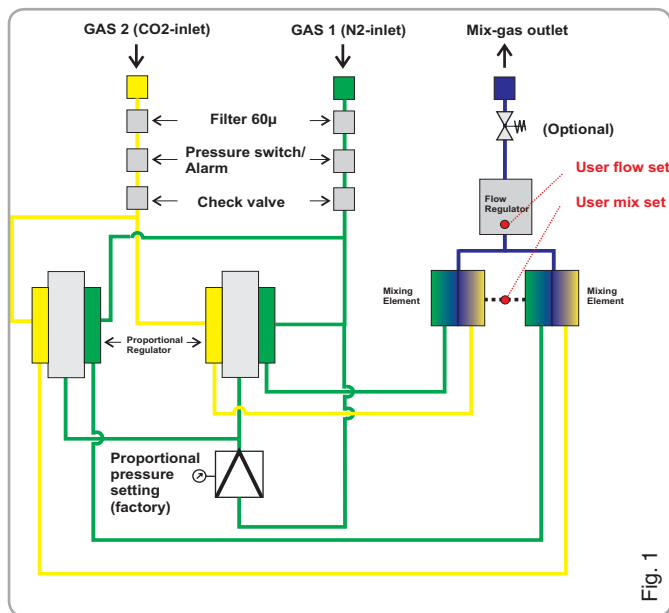

Fig. 1

## High Accuracy

An example of an unprecedented linearity in the 15-100% flow range and 10-90% mix settings. (See fig. 2).

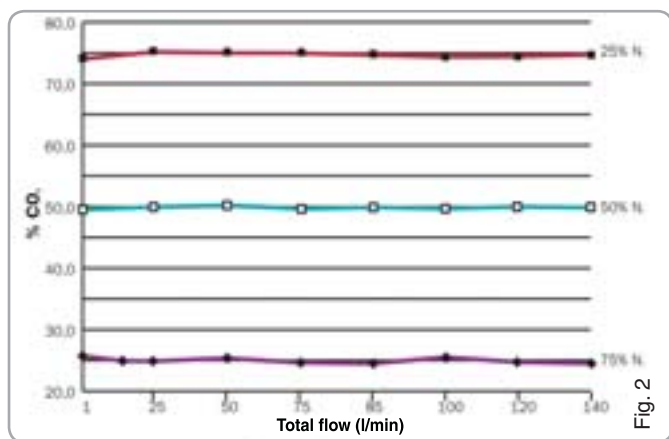

Fig. 2

## Technical specifications

General	
<b>Accuracy:</b>	Better than +/- 2% within 15 - 100% flow range and 10 - 90% mix settings
<b>Pressure:</b>	See below Flow shut off valve (optional/flow versions)
<b>Gas in / gas out:</b>	Rear panel
<b>Mixture adjustment:</b>	Proportional
<b>Alarms:</b>	Inlet pressure alarm with visual indication per gas and signal out (contact relay) on the rear panel. Acoustic alarm for too low gas inlet pressure
<b>Cabinet:</b>	Stainless steel

## Configurations

Model / for buffer:	Max. Outlet pressure:	Inlet pressure:	Press. switch:	Cabinet Dimention: (DxHxW) mm.	Approx. Weight:
<b>150L 2-gas</b>	3,5 bar	5-7 bar	Yes	420x194x235	9 Kg.
<b>150L 3-gas</b>	3,0 bar	6,5-8 bar	Yes	420x194x235	12 Kg.
<b>200L 3-gas</b>	5,0 bar	8-10 bar	Yes	420x194x235	13 Kg.
<b>250L 2-gas</b>	6,0 bar	8-10 bar	Yes	420x194x235	10 Kg.
<b>400L 2-gas</b>	6,0 bar	8-10 bar	Yes	420x194x235	11 Kg.
<b>400L 3-gas</b>	5,0 bar	8-10 bar	Yes	420x194x473	18 Kg.
<b>850L 2-gas</b>	6,0 bar	8-10 bar	Yes	420x194x473	16 Kg.
Model / flow:	Outlet pressure:	Inlet pressure:	Press. switch:	Cabinet dimension: (DxHxW) mm.	Approx. weight:
<b>150L 2-gas</b>	4,5 bar	5-7 bar	No	420x194x235	9 Kg.
<b>150L 3-gas</b>	4,0 bar	5-7 bar	No	420x194x235	12 Kg.
<b>200L 3-gas</b>	6,0 bar	8-10 bar	No	420x194x235	13 Kg.
<b>250L 2-gas</b>	7,0 bar	8-10 bar	No	420x194x235	10 Kg.
<b>400L 2-gas</b>	7,0 bar	8-10 bar	No	420x194x235	11 Kg.
<b>400L 3-gas</b>	7,0 bar	8-10 bar	No	420x194x473	18 Kg.
<b>600L 2-gas</b>	6,0 bar	8-10 bar	No	420x194x473	15 Kg.

Specifications apply to combinations of N<sub>2</sub>, CO<sub>2</sub> and O<sub>2</sub> but combination with other gases are available upon request.