

## MODEL MDMU - MINIATURE DISPLAY MODULE COUNTER/TIMER/TACH



- LCD, POSITIVE REFLECTIVE OR NEGATIVE TRANSMISSIVE WITH YELLOW/GREEN OR RED BACKLIGHTING
- COUNTER, TIMER, & TACH ALL IN A SINGLE UNIT
- RATE MULTIPLIER/PRESCALER FROM 0.0001 TO 1.9999 IN COUNT AND TACH MODES
- 10 RANGES IN TIMER MODE
- SELECTABLE DECIMAL POINTS
- 5 VDC POWERED
- PANEL MOUNT OR PC BOARD MOUNT

### DESCRIPTION

The MDMU is a complete 6 digit Counter/Timer/Tach in a small panel or printed circuit board mounted package. It is designed to operate from a 5 VDC power supply. It has a 6 digit LCD, with 0.35" high digits, and 5 selectable decimal points. In the timer modes, a flashing annunciator is supplied to indicate that the signal input of the MDMU is active. The displays are available in positive image reflective (black digits, reflective background) or negative image transmissive (illuminated digits, dark background) with red or yellow/green backlighting.

The MDMU has four Mode Select and three Decimal Point Select inputs available for determining the basic operation. Certain functions can also be selected through programming. In most applications, the MS and DP inputs are hard wired to select the appropriate function (counter, timer and tach) and decimal point position (counter and tach only). If changes to the MDMU configuration are required, or if a rate multiplier/prescale is desired, the PROGRAM input must be used to enter the appropriate information.

The COUNTER mode is selected by setting the Mode select inputs to the appropriate levels (Hardware selection). Decimal points may also be set using the DP Inputs (Hardware selection). If a prescale is required, a value of 0.0001 to 1.9999 and a decimal point of 0 through 0.00000 can be selected using the PROGRAM input. Either the Count (CNT) or LSC (digitally debounced input) inputs can be used.

*Note: If programming options are entered, the counter increments on the opposite edge of the input signal.*

The TIMER mode and range is selected by either setting the Mode Select inputs to the appropriate levels (Hardware selection) or by selecting the range using the PROGRAM input. The timing range increments available are 1 msec, 10 msec, 100 msec, 1 sec, 0.1 min, 1 min, 0.01 hr, 0.1 hr, 1 hr, and hr:min:sec. The TIMER ACTIVE annunciator will flash at a 2 Hz rate when the input to the timer is activated. Either the CNT or the LSC inputs can be used. The Inhibit (INH) input can be used to enable or disable Leading Zero Blanking (LZB).

The TACH mode can be selected by setting the Mode Select inputs to the appropriate levels (Hardware selection). In the tach mode, the MDMU operates as a fixed 1 second time base tachometer. Using the PROGRAM input, the time base can be set to 1 through 7 seconds (in whole second increments). The rate multiplier can also be programmed from 0.0001 thru 1.9999. Decimal points can be set from 0 thru 0.00000. Decimal points may also be set using the DP Inputs. Either the CNT or the LSC inputs can be used.

*Note: If Programming options are entered, the counter increments on the opposite edge of the input signal.*

The integrated circuit is bonded directly to the printed circuit board and is mechanically protected. Internal electrical interface connections use elastomeric connectors to provide a corrosion resistant connection. This reliable construction also reduces the space requirements.

### DIMENSIONS In inches (mm)

Note: Recommended minimum clearance behind the panel for mounting clip installation is 2.25" (57.2)W x 1.5" (38.1)H

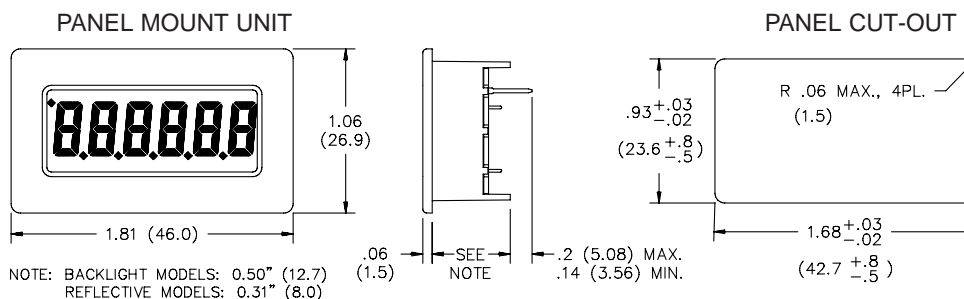

### PRINTED CIRCUIT BOARD MOUNT UNIT

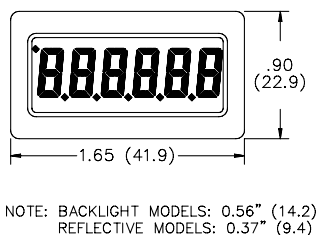

### RECOMMENDED PCB LAYOUT

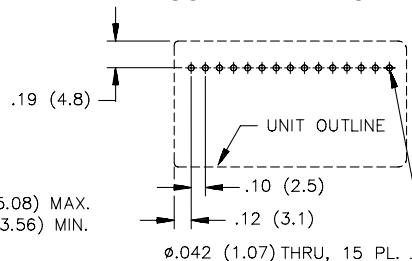

## SPECIFICATIONS

- DISPLAY:** 6 Digit LCD, 0.35" (8.89 mm) high characters, available in positive image reflective (black digits, reflective background) or negative image transmissive (illuminated digits, dark background) with red or yellow/green backlighting.
- POWER REQUIREMENTS:**
  - Reflective Versions:** 5.0 VDC  $\pm 10\%$  100  $\mu$ A max.
  - Backlight Versions:** 5.0 VDC  $\pm 10\%$  25 mA max.
- DECIMAL POINTS:**
  - Timer:** Determined by the timing mode selected.
  - Counter and Tach:** 5 programmable positions.
- ANNUNCIATOR:** Flashes at a 2 Hz rate in the Timer mode when the signal input (CNT or LSC) is activated.
- CONSTRUCTION:** High impact black plastic case (mounting clip included with panel mount models).
- RELATIVE HUMIDITY:** Less than 85% RH (non condensing)
- WEIGHT:**
  - Reflective Panel Mount:** 0.256 oz (7.26 g)
  - Reflective PCB Mount:** 0.24 oz (6.8 g)
  - Transmissive Panel Mount:** 0.368 oz (10.43 g)
  - Transmissive PCB Mount:** 0.344 (9.75 g)

## MAXIMUM RATINGS

RATING	SYMBOL	VALUE	UNITS	REMARKS
DC Supply Voltage	V <sub>DD</sub>	6.5	VDC	
Input Voltage, all inputs except LSC	V <sub>IN</sub>	-0.5 to (V <sub>DD</sub> +0.5)	VDC	
Input Voltage, LSC	V <sub>LSC</sub>	-0.5 to (V <sub>DD</sub> +0.5)	VDC	Higher voltages can be applied with an external resistor limiting the LSC input current to less than 450 $\mu$ A.
Operating Temperature	T <sub>A</sub>	-35 to +85	°C	
Storage Temperature	T <sub>STG</sub>	-40 to +85	°C	

## INSTALLATION

The MDMUs are available in either a panel mount or printed circuit board mount design. The panel mount units are provided with a mounting clip to securely hold the unit in the panel cutout.

### Panel Mount Installation:

- Cut panel opening to specified dimensions. Remove burrs and clean the panel opening.
- Install MDMU through the panel cutout as shown in Figure 1.
- Slide mounting clip over rear of unit until clip is against the back of panel. The unit has slots for the locking tabs to hold it in the panel opening.

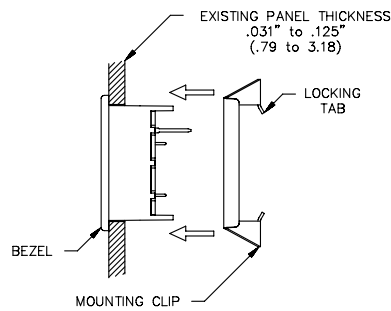

Figure 1

Note: Hold the MDMU front bezel in place when sliding the mounting clip in to position

### PCB Mount Installation:

- Prepare printed circuit board hole pattern to the specifications.
- Unit should be hand soldered using good soldering techniques and hand cleaned if necessary.

### CAUTION

This device contains CMOS circuitry which requires special anti-static handling to the same degree required by standard CMOS integrated circuits. Units should be stored in the conductive package used to ship the device. Containers should be opened and units handled only on a conductive table top by personnel wearing wrist-strap grounding equipment. These devices have the same protection circuits as standard CMOS devices to prevent damage to inputs due to nominal over-voltage.

## ELECTRICAL SPECIFICATIONS - V<sub>DD</sub> = 5.0 VDC $\pm 10\%$ @ 25°C unless otherwise specified.

SYMBOL	PARAMETER	MIN	TYP	MAX	UNITS	NOTES
V <sub>DD</sub>	Supply Voltage	4.5	5.0	5.5	VDC	Voltages outside these parameters may cause display problems
I <sub>DD</sub>	Supply Current - Transmissive		20	25	mA	V <sub>DD</sub> = 5.0 VDC - 10 KHz Counting Rate.
I <sub>DD</sub>	Supply Current - Reflective		35	100	$\mu$ A	V <sub>DD</sub> = 5.0 VDC - 10 KHz Counting Rate.
V <sub>IH</sub>	Valid High Voltage - CNT, LSC, PGM, INH (Count mode), LATCH, RST	3.5			VDC	
V <sub>IH</sub>	Valid High Voltage - MS1-4, DP1-3	3.0			VDC	
V <sub>IL</sub>	Valid Low Voltage - CNT, LSC, PGM, INH (Count mode), LATCH, RST			1.0	VDC	
V <sub>IL</sub>	Valid Low Voltage - MS1-4, DP1-3			1.0	VDC	
I <sub>IN</sub>	Input pulldown load current - LSC	0.5		5.0	$\mu$ A	V <sub>IN</sub> = 5.0 VDC. For input voltages greater than 5.0 V, current must be externally limited to less than 450 $\mu$ A.
I <sub>IN</sub>	Input leakage current - all other inputs		0.1	1.0	$\mu$ A	
F <sub>C</sub>	Count Frequency - CNT	500	1000		KHz	
F <sub>C</sub>	Count Frequency - LSC	0 30 42		30 42 225	Hz	MDMU increments on each pulse Indeterminate MDMU increments once for each burst of pulses
T <sub>R,L</sub>	RST, LATCH Pulse width.	10	0.5		$\mu$ sec	
ACCT	Timer Accuracy.			0.025	%	Using CNT input. If the LSC input is used, an additional error of up to 30 msec per activation may be accumulated.
ACCTB	Time Base Accuracy.			0.025	%	

### MODE SELECT INPUTS - Hardware Selection

The MDMU has 4 Mode Select Inputs, MS1 through MS4. The mode of operation is selected by setting these inputs to either the  $V_{DD}(1)$  or  $V_{SS}(0)$  states.

*Note: The MS Inputs are read only when power is applied to the MDMU. Any changes to the MS settings after power is applied will have an unpredictable effect on the operation of the MDMU.*

*Note: If the PGM features are used, only modes 0, 11, and 12 should be used. Refer to PROGRAMMING for more details.*

MODE SELECT INPUTS					MODE OF OPERATION
Mode	MS4	MS3	MS2	MS1	
0	0	0	0	0	0.001 Sec Timer and All PGM Timers
1	0	0	0	1	0.01 Sec Timer
2	0	0	1	0	0.1 Sec Timer
3	0	0	1	1	1 Sec Timer
4	0	1	0	0	0.1 Min Timer
5	0	1	0	1	1 Min Timer
6	0	1	1	0	0.01 Hr Timer
7	0	1	1	1	0.1 Hr Timer
8	1	0	0	0	1 Hr Timer
9	1	0	0	1	Hr:Min:Sec Timer
10	1	0	1	0	Not Used
11	1	0	1	1	1 Sec T.B. Tach and PGM Tach
12	1	1	0	0	Counter and PGM Counter

### DECIMAL POINT INPUTS - Hardware Selection

The Decimal Point Inputs can be used to select the desired position for a decimal point in the Counter and Tach modes. Using these inputs in any of the Timer modes, or when using the programming options, may cause unexpected results and should be tied low (0 V).

*Note: The DP Inputs are read only when power is applied to the MDMU. Any change to the DP inputs after power is applied will have an unpredictable effect on the operation.*

DECIMAL POINT INPUTS			DISPLAY
DP3	DP2	DP1	
0	0	0	0
0	0	1	0.0
0	1	0	0.00
0	1	1	0.000
1	0	0	0.0000
1	0	1	0.00000
1	1	0	.000000
1	1	1	000000

## PROGRAMMING

The MDMU's mode of operation (Counter, Timer, or Tach) can be modified by selecting the various features of the Program mode. The PROGRAM mode uses the PGM input to select the digit to be modified and to switch between Program features. The RST input is used to set the value of the specified digit. Both inputs are normally held HIGH and are pulsed LOW momentarily to make the selections desired. Once the PGM mode is entered, all Programming selections must be entered before returning to the operating mode.

**Notes:**

1. Only the modes specified for PGM features should be used for the Program mode (Timer - Mode 0, Tach - Mode 11, and Counter - Mode 12). Using the Programming features in other hardware selected modes may produce unexpected results. The PGM input should be tied high (+V) if programming is not desired.
2. All options entered by programming will be lost if power is removed from the unit
3. Upon entering the PGM mode for the first time, the Rate Multiplier/Prescaler is set to 0.0000. Some value between 0.0001 and 1.9999 must be entered in order for the MDMU to operate properly. Previously stored values are retained until changed by the user.

### Timer Mode Programming Options - Mode 0

#### Timer Mode Selection

When the MS Inputs are set for 0000, the MDMU will be placed into the 0.001 Sec timer mode. However, if the PGM input is pulsed, the MDMU will enter the PROGRAM mode, which will allow the unit to be set to any of the Timer ranges. These ranges will function the same as the ranges selected through using the MS Inputs (Hardware selection). When the PGM input is pulsed LOW, the MDMU display will change to 0. The 0 indicates the Timer Range or Mode number (0.001 Sec). If the RST Input is pulsed, the display will increment to 1 (0.01 Sec). Pulsing the RST Input again will continue to increment the display (and Timer range) until 9 is reached. At this time, the display will return to 0. Pulsing the PGM Input will return the previous display from the timer mode with the new timer range and decimal point position enabled. Any new time accumulated will be at the new rate.

*Note: To avoid incorrect display information, it is recommended that the MDMU be reset after making programming changes.*

### Tach Mode Programming Options - Mode 11

When the MS Inputs are set for 1011, the MDMU will be placed into the 1 Sec T.B. Tach mode. However, if the PGM input is pulsed, the MDMU will enter the PROGRAM mode, which will allow the rate multiplier, decimal point, and time base to be changed.

#### Rate Multiplier Selection

To enter the PROGRAM mode, the PGM Input should be pulsed LOW. The MDMU display will change to 0.0000 with the least significant digit (LSD) flashing at a 2 Hz rate. Pulsing the RST Input will cause the LSD to increment once for each pulse. After the digit has been incremented to 9, it will change back to a 0 on the next pulse of the RST Input. Pulsing the PGM input will lock in the present value of the LSD and the next digit will begin to flash. All subsequent digits will work the same until the most significant digit (MSD). This digit can only be set to a 0 or a 1.

#### Decimal Point Selection

Pulsing the PGM Input at this time will cause the unit to switch to the Decimal Point Selection mode. In this mode, the display will read 0.0000. Pulsing the RST Input will move the decimal point to the next position. The display will change from 0.00000 to 000000, then to 0, etc. Since the MDMU uses an integrated circuit which has 8 digit capability and the MDMU display is only 6 digits, the display will not appear to change after 000000 is displayed until the RST Input is pulsed twice. At this time the display will update to 0.

#### Time Base Selection

Pulsing the PGM Input will cause the unit to switch to the Time Base Selection mode. The display will indicate a 6 which selects a 6 second time base period. Pulsing the RST Input will allow the time base to be changed from 0 to 7 seconds (in whole second increments). A 0 time base will inhibit the MDMU from displaying the rate. Pulsing the PGM Input will return the unit to the Tach mode using the new time base selected and the new decimal point position. Any new rate pulses will be affected by the rate multiplier value.

### Counter Mode Programming Options - Mode 12

When the MS Inputs are set for 1100, the MDMU will be placed into the Counter mode. However, if the PGM input is pulsed, the MDMU will enter the PROGRAM mode, which will allow the prescaler, and decimal point settings to be changed.

#### Prescaler Selection

To enter the PROGRAM mode, the PGM input should be pulsed LOW. The MDMU display will change to 0.0000 with the least significant digit (LSD) flashing at a 2 Hz rate. Pulsing the RST input will cause the LSD to increment once for each pulse. After the digit has been incremented to 9, it will change back to a 0 on the next pulse of the RST input. Pulsing the PGM input will lock in the present value of the LSD and the next digit will begin to flash. All subsequent digits will work the same until the most significant digit (MSD). This digit can only be set to a 0 or a 1.

#### Decimal Point Selection

Pulsing the PGM input at this time will cause the unit to switch to the Decimal Point Select mode. In this mode, the display will read 0.0000. Pulsing the RST input will move the decimal point to the next position. The display will change from 0.00000 to 000000, then to 0, etc. Since the MDMU uses an integrated circuit which has 8 digit capability and the MDMU display is only 6 digits, the display will not appear to change after 000000 is displayed until the RST input is pulsed twice. At that time, the display will update to 0. Pulsing the PGM input will return the previous display from the counter mode with the new decimal point position enabled. Any new count pulses will be affected by the rate multiplier value.

*Note: The incrementing edge of the count signal will change when PROGRAM mode options are used. To avoid incorrect display information, it is recommended that the MDMU be reset after making programming changes.*

## INPUT CONDITIONS FOR DETERMINING COUNT EDGE

Accessing PROGRAM mode will complement the incrementing edge of the input signal.

COUNTER AND TACH				TIMER		
INPUT SIGNAL USED	OTHER INPUT TIED TO	INCREMENTING EDGE		NORMAL AND W/PGM OPTIONS		
		NORMAL	W/PGM	LSC	CNT	ACTION
LSC	V <sub>SS</sub>	Falling	Rising	V <sub>SS</sub>	V <sub>SS</sub>	RUN
	V <sub>DD</sub>	Rising	Falling	V <sub>SS</sub>	V <sub>DD</sub>	STOP
CNT	V <sub>SS</sub>	Falling	Rising	V <sub>DD</sub>	V <sub>SS</sub>	RUN
	V <sub>DD</sub>	Rising	Falling	V <sub>DD</sub>	V <sub>DD</sub>	RUN

## WIRING CONNECTIONS

The electrical connections are made via terminal pins located on the back of the unit. The terminal pins are on 0.100" center lines and can be mated with the RLC Model HWK7 cable assembly or many standard 0.100" center line connectors. When wiring the unit, refer to Figure 2 to identify the wire position with the proper function.

There are certain considerations that should be observed when running the signal wires. A length of wire can act like an antenna, and the closer it is to a source of electrical noise, the more it becomes susceptible to that noise.

These are a few rules that should be followed when running these wires.

1. Never run signal wires in the same conduit or raceway with A.C. power lines, conductors feeding motors, solenoids, SCR controls, heaters, etc.
2. Signal wires within enclosures should be routed as far away as possible from contactors, control relays, transformers, and other noisy components.
3. When shielded wire is used, connect the shield to the common of the MDMU unit, and leave the other end of the shield disconnected and insulated from machine ground.
4. Connect common of the MDMU to machine ground at one point only.

## PIN DESCRIPTIONS

(All unused inputs must be tied to high or low, whichever is appropriate)

- **V<sub>DD</sub>** : +5.0 VDC  $\pm$  10% supply terminal. A clean power supply is required for the proper operation of the MDMU. A slow voltage rise at power up may cause erratic operation.
- **DP1, DP2, DP3** : The Decimal Point Select Inputs are used to select the desired decimal point position. These inputs are intended to be used in the non-programmed Counter and Tach modes only. To avoid conflicts with the decimal points set with the programming options, or by the Timer ranges, these inputs should be left tied to V<sub>SS</sub>.
- **MS1, MS2, MS3, MS4** : The Mode Select Inputs are used to select the mode of operation: Counter, Timer and Tach. The Timer range can also be selected using the MS inputs. If programming is required, modes 0 (Timer), 11 (Tach), or 12 (Counter) should be used.
- **RST** : Schmidt trigger input. In the Counter and Timer modes, a LOW level on the RST input will reset the display and all internal divider registers to 0.

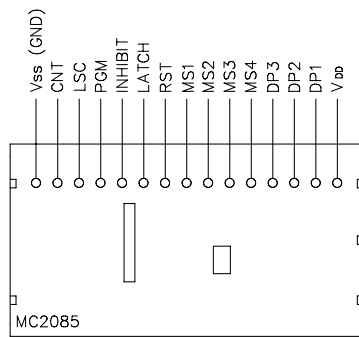

Figure 2

When the RST input is in the HIGH state, the counter/timer will operate normally. The RST input should be tied high and not used in the Tach mode. The RST input is also used in the PROGRAM modes to increment the selected digit.

- **LATCH** : Schmidt trigger input. In the Counter and Tach modes, a HIGH level on the LATCH input will freeze the display while allowing the counter or timer to continue to accept the signal input. When the LATCH input is in the LOW state, the counter/timer will operate normally. The LATCH input should be tied low and not used in the Tach mode.
- **INHIBIT** : Schmidt trigger input. In the Counter and Tach modes, a LOW level on the INHIBIT input will prevent further signal inputs from incrementing the counter or tach. When the INHIBIT input is in the HIGH state, the counter/tach will operate normally. For Timer modes, a LOW level on the INHIBIT input will enable leading zero blanking while a HIGH level on the INHIBIT input will disable the LZB.
- **PGM** : Schmidt trigger input. A momentary LOW pulse on the PGM will put the MDMU into the PROGRAM mode. Further pulsing of the PGM input will step through the various digit positions or to the next programming option. A final pulse of the PGM input will return the MDMU to the normal operating mode.
- **LSC** : The Low Speed Signal Input (working in conjunction with the CNT Input) is one of the two signal sources for all of the counting, timing, and tach functions of the MDMU. The LSC input is able to accept low frequency signal voltages in excess of V<sub>DD</sub> (Input current must be limited to less than 450  $\mu$ A to prevent damage to the unit). In the COUNT mode, the LSC input is internally filtered so that signals below 30 Hz are registered as individual count pulses. Signals from 42 Hz to 225 Hz are treated as a single burst (each burst of pulses is treated as a single count). In the TIMER modes, the LSC input can be used to actuate the timer.

Notes:

1. Due to the internal digital filtering to the LSC input, up to 30 msec of error may be added per activation of the LSC input.
  2. Although the LSC and CNT inputs will work at the same time, it is not advised since there is no Anti-coincidence provided.
  3. Although the LSC input can be used in the TACH mode, it may not be practical since the usable frequency is limited to 30 Hz.
- **CNT** : Schmidt trigger input. The Count input (working in conjunction with the LSC input) is one of the two signal sources for all of the counting, timing, and tach functions of the MDMU. The CNT input is able to accept high frequency signals with an amplitude of 5.0 VDC. *Note: Although the LSC and the CNT inputs will work at the same time, it is not advised since Anti-coincidence is not provided.*
  - **V<sub>SS</sub>** : GND or Common supply terminal.

## TYPICAL APPLICATIONS

**COUNTER** - Displays the number of activations of solenoid. Counts increments on the rising edge of LSC. Display decimal point is set to 0.00. D1 prevents LSC input from negative swing of input signal. R1 value is selected to prevent input current from exceeding 450  $\mu$ A. The solenoid is activated by an external AC power source.

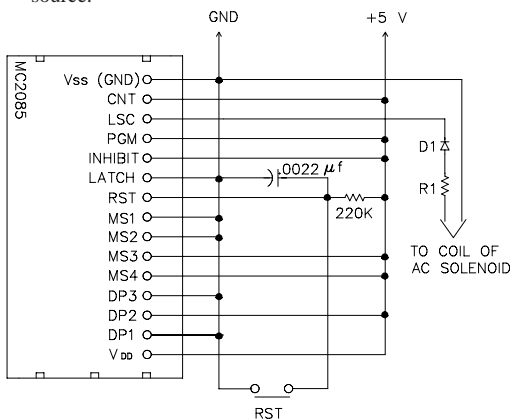

Note: All inputs will be at line potential

**1 MINUTE TIMER** - With Leading Zero Blanking enabled. Time starts with the switch closed. Time stops and holds the display with the switch open.

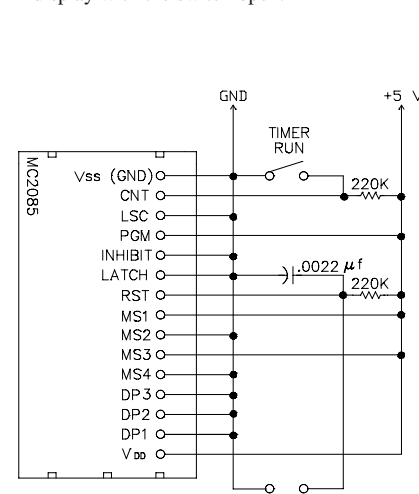

**TACH** - With user programmed rate multiplier, decimal point position and time base. Falling Edge triggered.

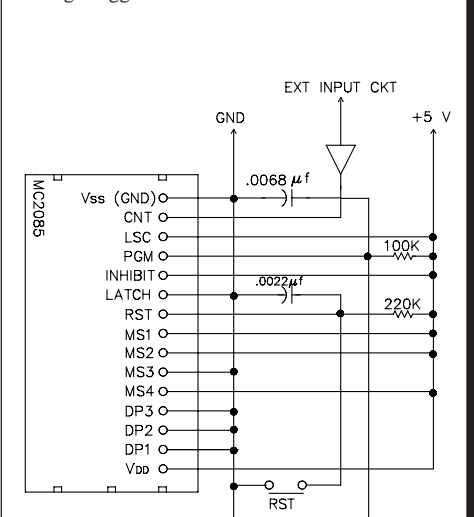

## PROGRAMMING EXAMPLES

### SCALING A COUNTER

**Example:** An encoder generates 600 pulses per foot. The Desired Display is tenths of inches. The Prescaler is determined using the formula below.

$$\text{Prescaler} = \frac{\text{Desired Display Units} \times \text{Decimal Point Value}}{\text{Number of Pulses}}$$

#### Where:

**Desired Display** = The number of Desired Display units (revolutions, feet, 10ths of feet, meters, etc.).

**Number of Pulses** = The number of pulses required to achieve the Desired Display

**Decimal Point Value** = The desired decimal point placement on the display.

Decimal Point Value	Multiply By
0	1
0.0	10
0.00	100
0.000	1000
0.0000	10000
0.00000	100000

**Example:** Display tenths of inches when using

$$\text{Prescaler} = \frac{1 \text{ (inch)} \times 10 \text{ (Decimal Point Value)}}{600 \text{ pulses/foot} \times 1 \text{ foot/12 inches}}$$

$$= 10/50 = 0.2$$

### SCALING FOR RATE

For a Time Base (TB) of 1 second, the Rate Multiplier (RM) equals a Desired Display (DD) divided by the Pulses per Second (PPS) at that DD value. For other time bases, the PPS must be multiplied by the desired TB.

$$\text{RM} = \frac{\text{Desired Display value}}{\text{PPS @ DD value} \times \text{Time Base}}$$

When display units are a function of RPM then,

$$\text{RM} = \frac{\text{Desired Display} \times \text{Decimal Point Value} \times 60}{\text{RPM (@DD)} \times \text{PPR} \times \text{TB}}$$

**Example 1:** Show inches per minute with an encoder generating 600 pulses per foot, with a 1 foot circumference wheel.

**Step 1:** Since the rate is in minutes, we choose 6 inches as the desired display.

**Step 2:** Use the general formula.

$$\text{RM} = \frac{6 \text{ in/min} \times 1 \times 60}{0.5 \text{ RPM} \times 600 \text{ pulses/foot} \times 1 \text{ sec.}}$$

$$\text{RM} = 1.2$$

**Example 2:** A belt moves 1 foot for 4 revolutions of a shaft. The shaft encoder generates 60 PPR. Show the rate in feet per minute with one decimal place.

$$\text{RM} = \frac{1 \text{ foot/min} \times 10 \times 60}{4 \text{ RPM} \times 60 \text{ PPR} \times 1 \text{ sec}}$$

$$\text{RM} = 2.5$$

This value is above the available range of 0.0001 to 1.9999. Increasing the Time Base to 2 sec. will allow us to decrease the rate multiplier needed to 1.25 which is within the available range. The same result could be achieved by increasing the pulses per revolution generated.

$$\text{RM} = \frac{1 \text{ foot/min} \times 10 \times 60}{4 \text{ RPM} \times 60 \text{ PPR} \times 2 \text{ sec}}$$

$$\text{RM} = 1.25$$

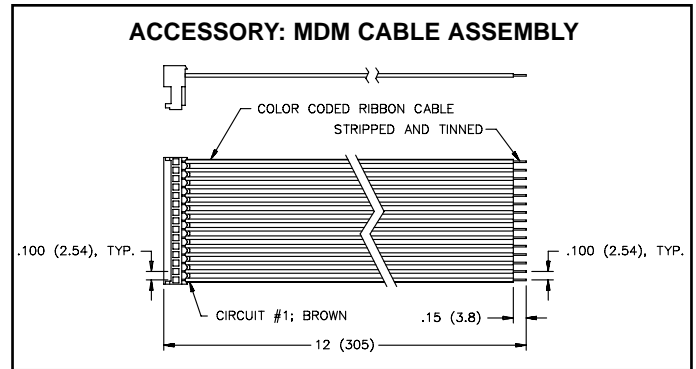

## ORDERING INFORMATION

MODEL NO	DESCRIPTION	PART NUMBER
MDMU	Panel Mount W/Reflective Display	MDMU0000
	Panel Mount W/Yel-Grn Backlighting	MDMU0010
	Panel Mount W/Red Backlighting	MDMU0020
	PC Board Mount W/Reflective Display	MDMU0100
	PC Board Mount W/Yel-Grn Backlighting	MDMU0110
	PC Board Mount W/Red Backlighting	MDMU0120
HWK7	MDM Cable Assembly	HWK70000

This page intentionally left blank.

This page intentionally left blank.

#### LIMITED WARRANTY

The Company warrants the products it manufactures against defects in materials and workmanship for a period limited to one year from the date of shipment, provided the products have been stored, handled, installed, and used under proper conditions. The Company's liability under this limited warranty shall extend only to the repair or replacement of a defective product, at The Company's option. The Company disclaims all liability for any affirmation, promise or representation with respect to the products.

The customer agrees to hold Red Lion Controls harmless from, defend, and indemnify RLC against damages, claims, and expenses arising out of subsequent sales of RLC products or products containing components manufactured by RLC and based upon personal injuries, deaths, property damage, lost profits, and other matters which Buyer, its employees, or sub-contractors are or may be to any extent liable, including without limitation penalties imposed by the Consumer Product Safety Act (P.L. 92-573) and liability imposed upon any person pursuant to the Magnuson-Moss Warranty Act (P.L. 93-637), as now in effect or as amended hereafter.

No warranties expressed or implied are created with respect to The Company's products except those expressly contained herein. The Customer acknowledges the disclaimers and limitations contained herein and relies on no other warranties or affirmations.