

LE 09E, LE 09S, LE 09SE LIQUID HANDLING ASSEMBLIES with 0.9 Liquifram™

CAUTION

When pumping chemicals make certain that all tubing is securely attached to the fittings. It is recommended that tubing or pipe lines be shielded to prevent possible injury in case of rupture or accidental damage. Always wear protective clothing when working on or near chemical metering pump.

A. INSTALLING INJECTION CHECK VALVE

1. The injection check valve should always be installed as close as possible to the point of chemical injection, at the very end of the tubing run.
2. Purpose of injection check/back pressure valve is to prevent backflow from *treated line* and to prevent syphoning or overpumping of chemical.
3. A 1/2" NPT female fitting with sufficient depth will accept the injection check/back pressure valve.
4. In order to insure correct seating of the ball inside the check valve, the injection check/back pressure valve should be installed upwards.

B. CONNECTING DISCHARGE TUBING

NOTE: Cut tubing to length needed for discharge line.

1. Route tubing from injection check valve to chemical metering pump making sure it does not touch hot surfaces, sharp surfaces, or is bent so sharply that it kinks.
2. Slide small end of coupling nut onto tubing.
3. Slide the long, straight end of the ferrule onto tubing so that tubing exits at the cone shaped end of the ferrule.
4. Insert tubing into discharge valve housing so that tubing butts up against valve housing and will not go any further.
5. Slide ferrule down so that cone shaped end fits snugly into discharge valve housing.
6. Slide down the coupling nut until threads are engaged. Tighten coupling nut by hand, maintaining pressure on tubing towards valve housing until tubing is held securely in place.

Excessive force will crack or distort fittings. DO NOT USE PIPE WRENCH.

7. Follow same procedure for connecting tubing to injection valve.

MATERIALS

Fittings	GFR Polypropylene
Seal Rings	Polyprel
Balls	Ceramic
Head	Polypropylene
Liquifram	Teflon Face
Suction	.250" O.D. Vinyl
Discharge	.250" O.D. Polyethylene

C. CONNECTING SUCTION TUBING

1. Cut suction tubing to a length such that the foot valve hangs just above the bottom of the chemical container. Maximum recommended vertical suction lift is 5 ft. (1.5m).
2. Follow same procedure (see B) in connecting suction tubing to suction valve and foot valve.

D. PRIMING—FOR LE 09E

1. Temporarily remove tubing from injection check/back pressure valve and hold the end of tubing so it is above pump level.
2. Set pump at 80% speed and 100% stroke and start pump.
3. As soon as chemical is visible through translucent discharge tubing just past the discharge valve, stop the pump.
4. Pump is now primed.
5. Reconnect tubing to injection check/back pressure valve.

E. PRIMING—FOR LE 09S, LE 09SE

1. Connect pressure release tubing to pressure release port.
2. Route tubing to solution reservoir and anchor with plastic tie provided.
3. Set pump at 80% speed and 100% stroke. Start pump.
4. Pull on Pressure Release knob (red or black knob), holding knob out until chemical is visible through translucent return tubing.
5. Pump is now primed.

F. DEPRESSURIZING DISCHARGE LINE— FOR LE 09S, LE 09SE

1. It is possible to depressurize discharge line and pump head without removal of tubing or loosening of fittings.

Be sure injection check valve is properly installed and is operating. If a gate valve or globe has been installed, downstream of injection check valve, it should be closed. Be certain relief tubing is connected and run to chemical reservoir.

2. Pull on both anti-syphon and relief knobs.
3. The discharge line is now depressurized.
4. If injection check valve is of higher elevation than pump head, disconnecting tubing at injection check valve end will allow air to enter and cause chemical to drain back to tank.

NOTE:

- (a) Pump is normally self-priming if suction lift is no more than 5 ft. (1.5m), valves in the pump are wet with water (pump is shipped from factory with water in pump head) and the above steps (D1 thru D5 or E1 thru E5) are followed.
- (b) If the pump does not self prime, remove discharge valve housing or Anti-Syphon/Pressure Release Valve Assembly and discharge valve ball, and pour water or chemical slowly into discharge port until head is filled. Replace valve ball and follow appropriate priming instructions thereafter.



LIQUID METRONICS INCORPORATED

19 Craig Road, Acton, MA 01720-5495 U.S.A. Tel: (617) 263-9800 TLX: 95-1781

LIQUID HANDLING ASSEMBLY SERIES 09

IMPORTANT—TUBING USAGE

NEVER USE VINYL TUBING ON DISCHARGE SIDE OF PUMP! For use with chemicals such as sodium hypochlorite, alkalis, caustic soda, use part No. 27231-04 clear, flexible vinyl tubing on suction side and part No. 25636-10 translucent, stiff polyethylene tubing on discharge side. Minimize suction length.

For use with harsh chemicals such as strong acids (sulfuric acid) use part No. 25636-10 translucent, stiff polyethylene tubing on BOTH suction and discharge sides. Minimize suction length. **DO NOT USE VINYL TUBING WHEN PUMPING CONCENTRATED ACIDS OR SOLVENTS!**

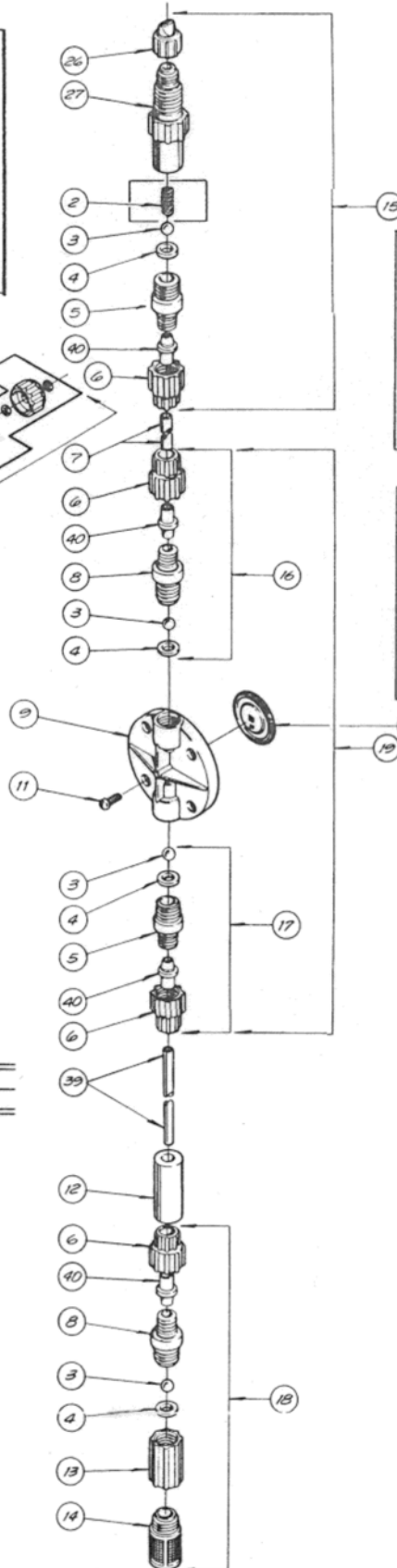
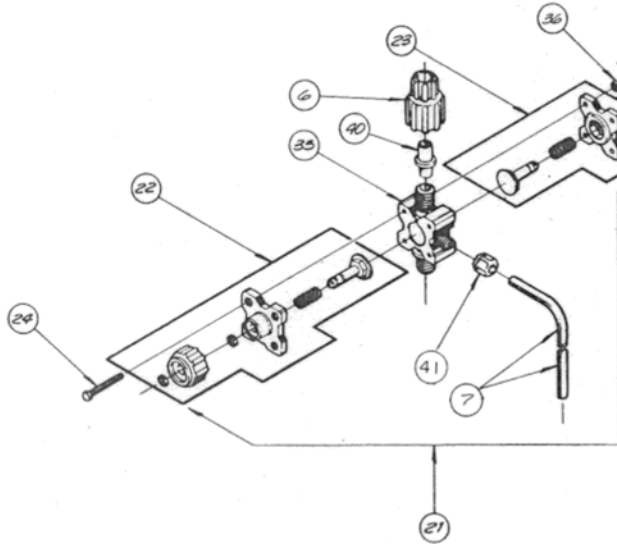

1. Maximum pump pressure rating is reduced by 25 psi (1.7 bar) with anti-syphon spring installed.
2. Do not remove anti-syphon spring if pressure at injection point is less than 15 psi (1.0 bar).

NOTE:
Threaded connections into pump head are 3/4"-16 straight threads. **Do not use Teflon tape.** These joints are sealed by seal ring valve seats (Item 4 on exploded view).

10 NOT INCLUDED IN 19

LE 09 SERIES

Ref. No.	Part No.	Description	Quantity		
			LE-09E	LE-09S	LE-09SE
2	10339*	Spring	1	0	1
3	10338*	Ball, Ceramic	4	3	4
4	27607*	Seal Ring, Polyprel™	4	3	4
5	28664	Valve Seat	2	1	2
6	10299	Coupling Nut	4	3	4
7	25636-10	Tubing, .250" OD Polyethylene	1	2	2
8	28665	Valve Housing	2	1	1
9	25960	Head	1	1	1
10	26041*	Liquifram™	1	1	1
11	10340	Screw, S.S.	4	4	4
12	10322	Weight, Ceramic	1	1	1
13	10978	Foot Valve Seat	1	1	1
14	10123	Strainer	1	1	1
15	28001	Injection Check/Back Pressure Valve	1	0	1
16	28005	Discharge Valve Assembly	1	0	1
17	28004	Suction Valve Assembly	1	0	0
18	28002	Foot Valve Assembly	1	1	1
19	27294	Head Assembly, 09E	1	0	0
19	27791	Head Assembly, 09S, 09SE	0	1	1
21	28010	Anti-Syphon/Pressure Release	0	1	1
22	28446	Relief Cap Assembly	0	1	1
23	25838	Anti-Syphon Cap Assembly	0	1	1
24	25627	Screw	0	4	4
26	27352	Flapper Valve	1	0	1
27	10394	Injector Fitting	1	0	1
35	28703	Valve Body	0	1	1
36	25628	Nut, S.S.	0	4	4
39	27231-04	Tubing, .250" OD Vinyl	1	1	1
40	28663	Ferrule	4	4	4
41	25631	Coupling Nut	0	1	1

*Parts included in Spare Parts Kit No. SP-09